

**FATEK**

FACTORY AUTOMATION TECH. CO., LTD.

☎ +886-5-213-3166

☎ +886-5-220-5293

✉ global@femco.com.tw

📍 No.26, Zhongshan Rd., Minxiang Tp.,  
Chiayi, 621, Taiwan

www.FATEK.com.tw



CNC HORIZONTAL  
BORING & MILLING  
MACHINE

BMC SERIES

**FATEK**

**FEMCOUSA**

☎ +1(714) 898-2066

🌐 www.femcousa.com

✉ Sales@Femcousa.com

📍 7142 Belgrave Ave,  
Garden Grove, CA 92841

**FEMCOINDIA**

☎ + 91-20-66787605

🌐 www.femcoindia.com

✉ sales@femcoindia.com

📍 Global Raisonni Ind.Park  
Gat No.182-184  
Nr.Lonikand, Phulgaon,  
Pune-412216 ( Maharashtra State )

**FEMCOTHAILAND**

☎ +66-2-033-5001-3 /  
093-124-7842

🌐 www.femcothailand.com

✉ salesthailand@femcothailand.com

📍 No.999 Gaysorn Center, Level 6,  
Unit 6A-7, Ploenchit Road, Lumpini,  
Pathumwan, Bangkok 10330

# BMC<sub>SERIES</sub>

## BMC 110 SERIES

BMC-110R1 / R2 / R3  
BMC-110T2 / T3 / T4  
BMC-110R1APC

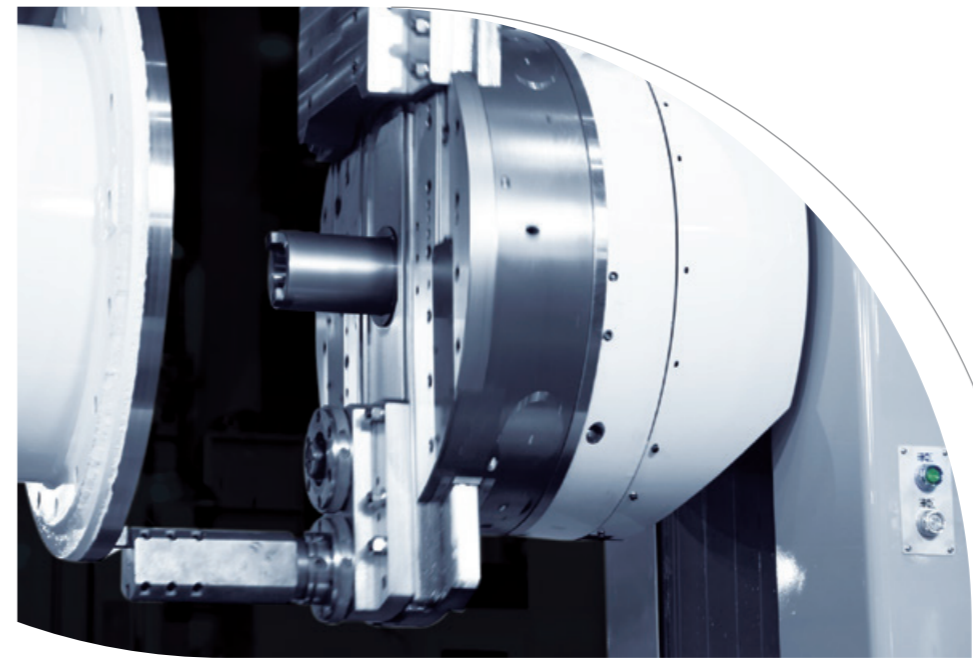

## FACING HEAD SERIES

**FT** BMC-110FT2 / FT3 / FT4  
T Type Construction Base

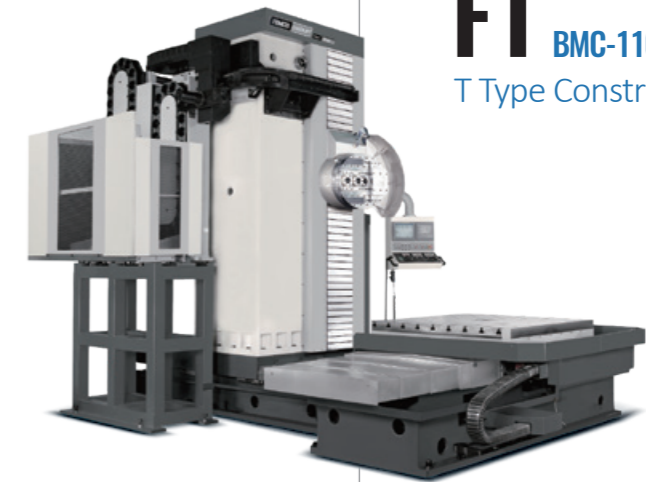

## BMC 135 SERIES

BMC-135TN/RN



## HIGH SPEED SERIES

BMC-100HT  
BMC-250T

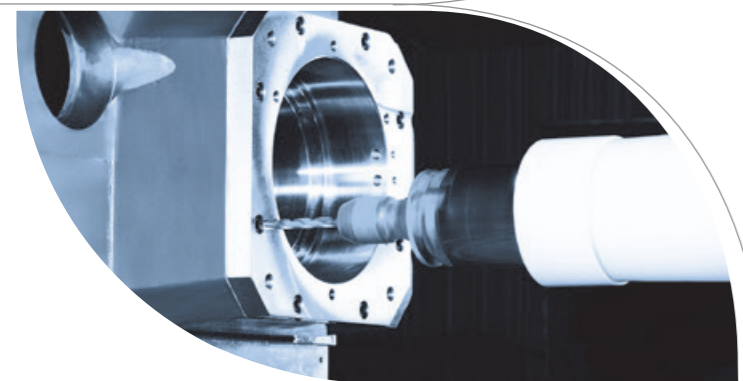

## FLOOR TYPE SERIES

FB-135



**FR** BMC-110FR1 / FR2 / FR3  
R Type Construction Base

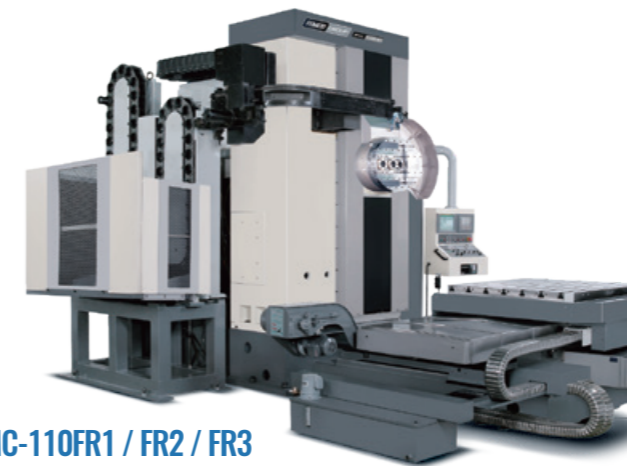

**RF** BMC-110R1F  
The Multi-working Model





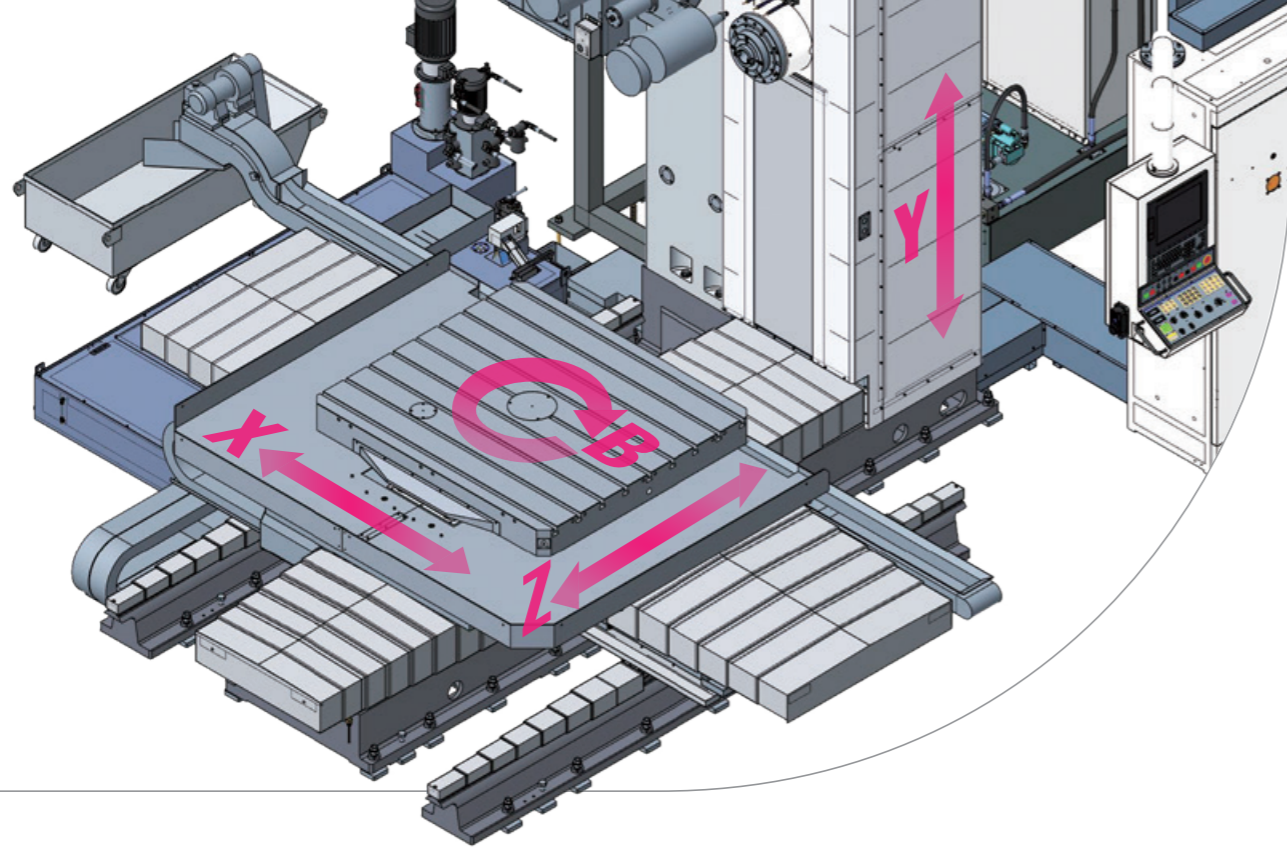

# 110 R Serie

## FIXED COLUMN TYPE

High Stability · High Efficiency

### Features

**X Axis Maximum Travel** : 3000 mm

**Y Axis Maximum Travel** : 1780 mm

**Z Axis Maximum Travel** : 1650 mm

**W Axis** : 500 mm

**Table Load Max. Capacity** : 6300 kgs

Spindle constructed of wear resistant, high tensile strength alloy steel with a Hardness of more than HV1000

**Spindle Max. Speed** : 2500 rpm

**Spindle Max. Torque** : 1504 Nm

- All primary structural components are composed of high quality cast iron
- Fixed column construction
- 4+1 axis and 4 axis simultaneous
- Standard table size 1440 mm X 1600 mm
- B Axis design integrates two worm gears to minimize backlash; incorporates high precision encoder (rotary scale) for 0.001 degree precision table rotation
- X, Y, Z Axis Linear Scales (Standard)
- FANUC (standard)  
Heidenhain, Siemens (option)

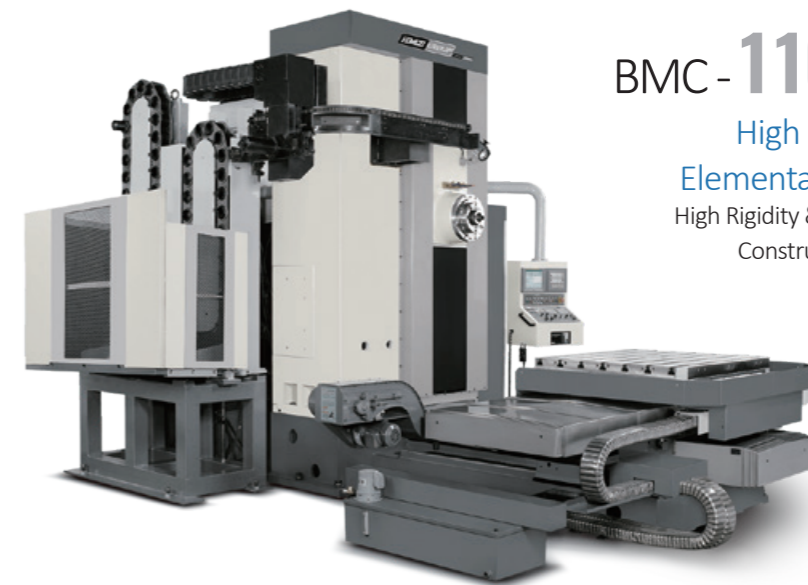

## BMC - 110R1

High Efficiency  
Elementary Model  
High Rigidity & Full Casting  
Construction Design

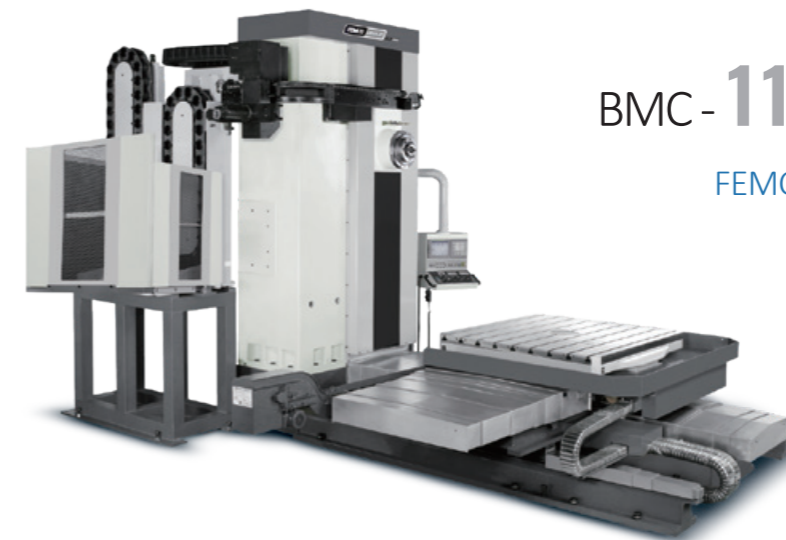

## BMC - 110R2 / R3

FEMCO BMC Best Seller  
The Best Selection of  
High Stability Models

	110R1	110R2 / R3
<b>X Axis Travel</b>	1400 mm	2000 / 3000 mm
<b>Y Axis Travel</b>	1390 mm	1780 mm
<b>Z Axis Travel</b>	1050 mm	1650 mm
<b>W Axis Travel</b>	500 mm	500 mm
<b>Spindle Speed</b>	2500 rpm	2500 rpm
<b>Spindle Bar Dia.</b>	110 mm	110 mm
<b>B Axis Table</b>	0.001 degree indexing	0.001 degree indexing
<b>Table size</b>	1120 mm X 1250 mm	1440 mm X 1600 mm
<b>Table Load Capacity</b>	4000 kgs.	6300 kgs.

### Optional Equipment



60 / 90T  
ATC

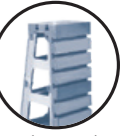

Right Angle  
Work Table

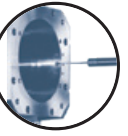

Work Piece  
Measurement



Tool Length  
Probe

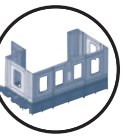

Splash Guard



720mm  
Facing Head



Facing Tool



90 Degree  
Angle Head



Manual Universal  
Milling Head



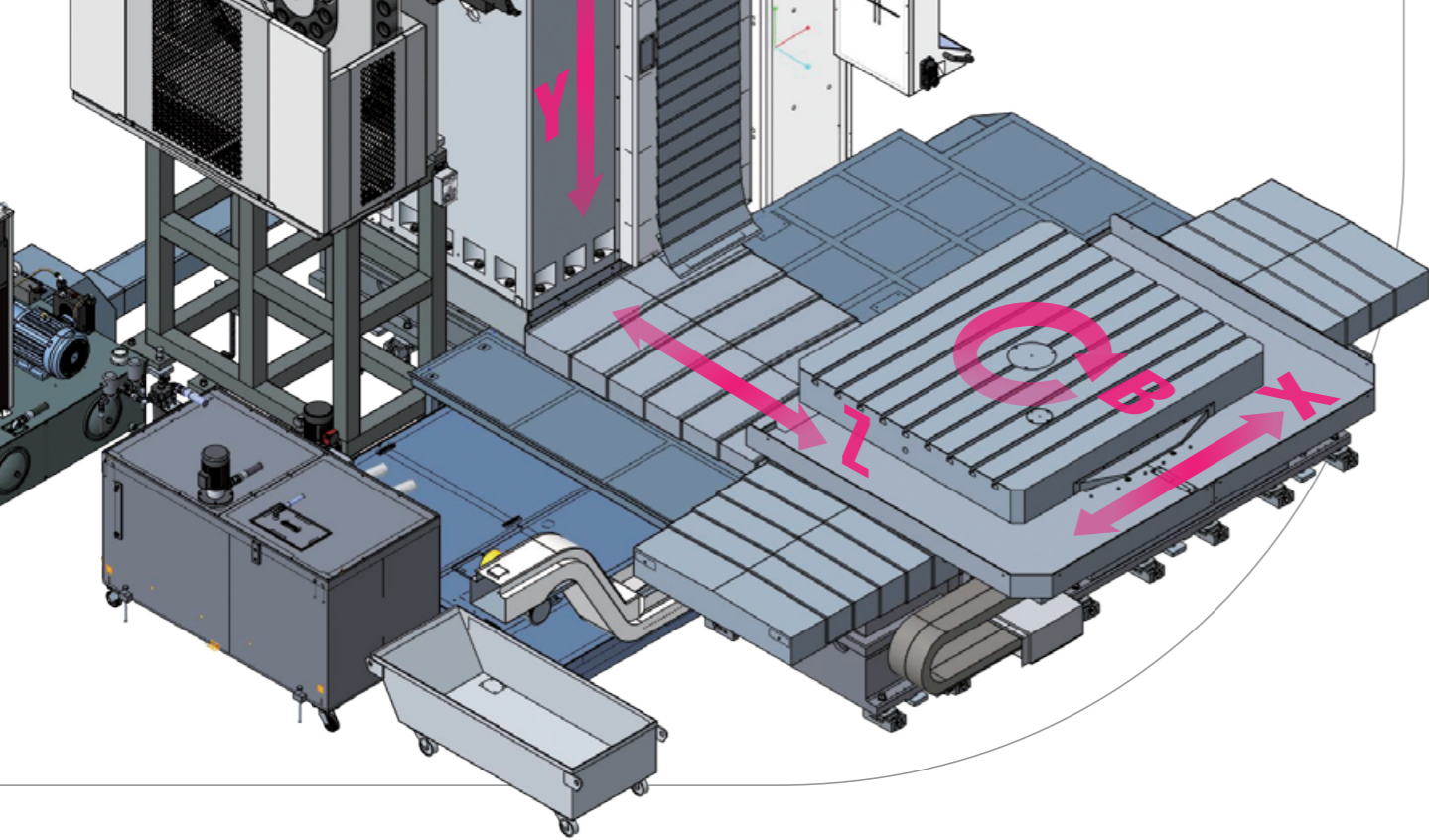

# 110 T Serie

## MOVING COLUMN TYPE

Heavy Table Loading Capacity

### Features

**X Axis Maximum Travel** : Up to 4000 mm

**Y Axis Maximum Travel** : 2050 mm

**Z Axis Maximum Travel** : 1500 mm

**W Axis** : 500 mm

**Table Load Max. Capacity** : 8000 kgs

Spindle constructed of wear resistant, high tensile strength alloy steel with a Hardness of more than HV1000

**Spindle Max. Speed** : 2500 rpm

**Spindle Max. Torque** : 1504 Nm

- All primary structural components are composed of high quality cast iron
- Moving column design, high table load capacity, rigid construction
- 4+1 axis and 4 axis simultaneous
- Standard table size 1440 mm X 1600 mm
- B-Axis design integrates two worm gears to minimize backlash; incorporates high precision encoder (rotary scale) for 0.001 degree precision table rotation
- X, Y, Z Axis Linear Scales (Standard)
- FANUC (standard)  
Heidenhain, Siemens (option)

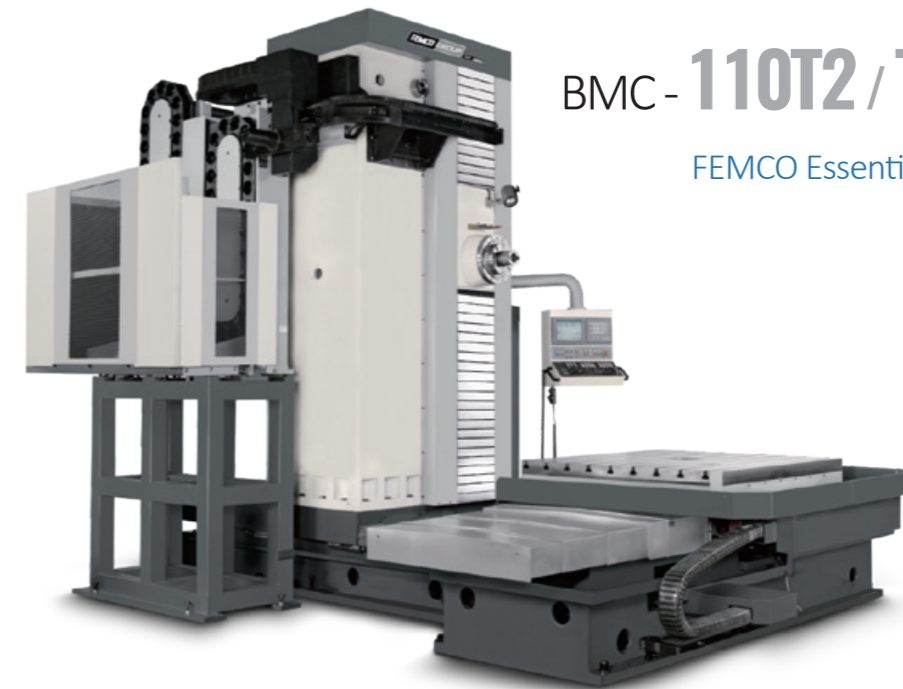

BMC-110T2 / T3 / T4

FEMCO Essential Boring Mills

### Powerful Headstock High Torque Precise Table

BMC-110T Series Machines represents the classical of table type horizontal borers that are currently on the market. Gear drive headstock equipped with powerful spindle, brings high torque power with excellent precision heavy loading table. BMC-110T series can fulfill the needs of the most demanding customers.

### 110T2 / T3 / T4

<b>X Axis Travel</b>	2000 / 3000 / 4000 mm
<b>Y Axis Travel</b>	2050 mm
<b>Z Axis Travel</b>	1500 mm
<b>W Axis Travel</b>	500 mm
<b>Spindle Speed</b>	2500 rpm
<b>Spindle Bar Dia.</b>	110 mm
<b>B Axis Table</b>	0.001 degree indexing
<b>Table size</b>	1440 mm X 1600 mm
<b>Table Load Capacity</b>	8000 kgs.

### Optional Equipment

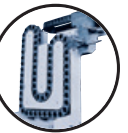

60 / 90T  
ATC

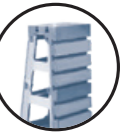

Right Angle  
Work Table

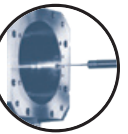

Work Piece  
Measurement



Tool Length  
Probe



Splash Guard



720mm  
Facing Head



Facing Tool



90 Degree  
Angle Head



Manual Universal  
Milling Head

# 135 Series

## THE CHOICE FOR HEAVY INDUSTRY

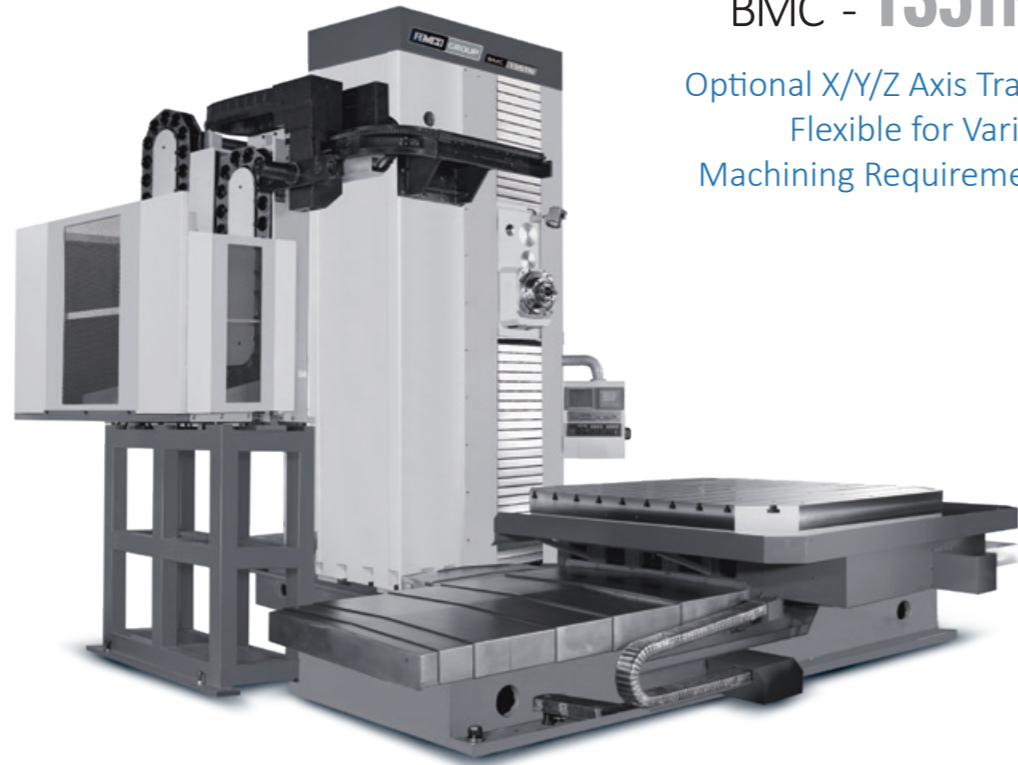

BMC - **135TN** ⌵  
 Optional X/Y/Z Axis Travel,  
 Flexible for Various  
 Machining Requirements

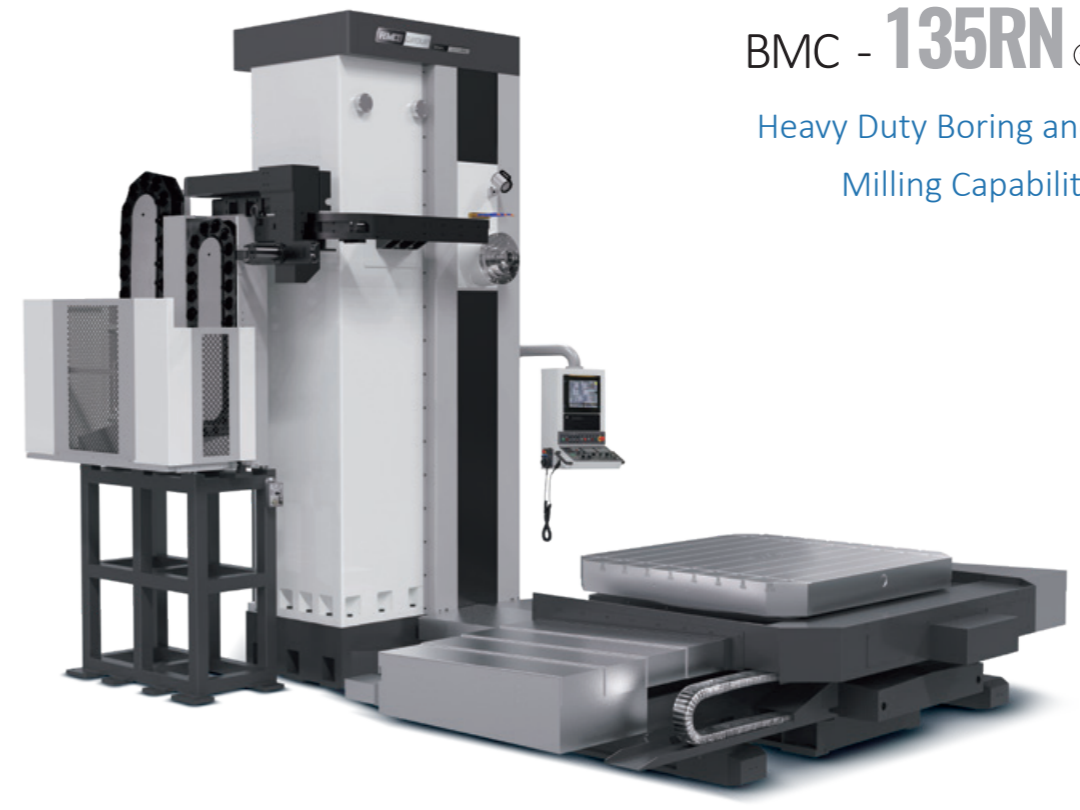

BMC - **135RN** ⌵  
 Heavy Duty Boring and  
 Milling Capability

### 135TN

<b>X Axis Travel</b>	3000 / 4000 mm
<b>Y Axis Travel</b>	2500 / 3000 mm
<b>Z Axis Travel</b>	1500 / 2000 mm
<b>W Axis Travel</b>	800 mm
<b>Spindle Speed</b>	3000 rpm
<b>Spindle Bar Dia.</b>	135 mm
<b>B Axis Table</b>	0.001 degree indexing
<b>Table size</b>	2200 mm X 2200 mm
<b>Table Load Capacity</b>	15000 kgs.

### 135mm Spindle Diameter Moving Column Construction

BMC-135TN represents large spindle diameter of FEMCO BMC series.

BMC-135TN can perform extreme precision machining, powerful milling and drilling processes among similar machines in the market.

This machines can be individually tailored to meet the costumer's requirements by choosing from comprehensive options and equipment.

### 135RN

<b>X Axis Travel</b>	2400 mm
<b>Y Axis Travel</b>	2500 mm
<b>Z Axis Travel</b>	1500 mm
<b>W Axis Travel</b>	800 mm
<b>Spindle Speed</b>	3000 rpm
<b>Spindle Bar Dia.</b>	135 mm
<b>B Axis Table</b>	0.001 degree indexing
<b>Table size</b>	1800 mm X 2000 mm
<b>Table Load Capacity</b>	10000 kgs.

### 135mm Spindle Diameter Fixed Column Construction

With many years of innovating the design of BMC-135TN, FEMCO has decided to present BMC-135RN, the fixed column type heavy loading machine for our customers.

Same as BMC-135TN, 135RN provides various comprehensive options to satisfy the demands of clients and achieve flexibility during processing.

Optional Equipment



60 / 90T  
ATC



Right Angle  
Work Table

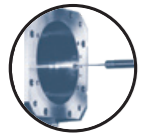

Work Piece  
Measurement



Tool Length  
Probe



Splash Guard



Extension  
Sleeve



90 Degree  
Angle Head



Manual Universal  
Milling Head



Linear Scale  
(HDH)

Optional Equipment



60 / 90T  
ATC



Right Angle  
Work Table

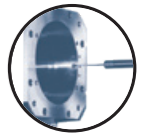

Work Piece  
Measurement



Tool Length  
Probe



Splash Guard



Extension  
Sleeve



90 Degree  
Angle Head



Manual Universal  
Milling Head



Linear Scale  
(HDH)



# HIGH SPEED Series

## BMC - 100HT

Excellent Machining Capability of Molding

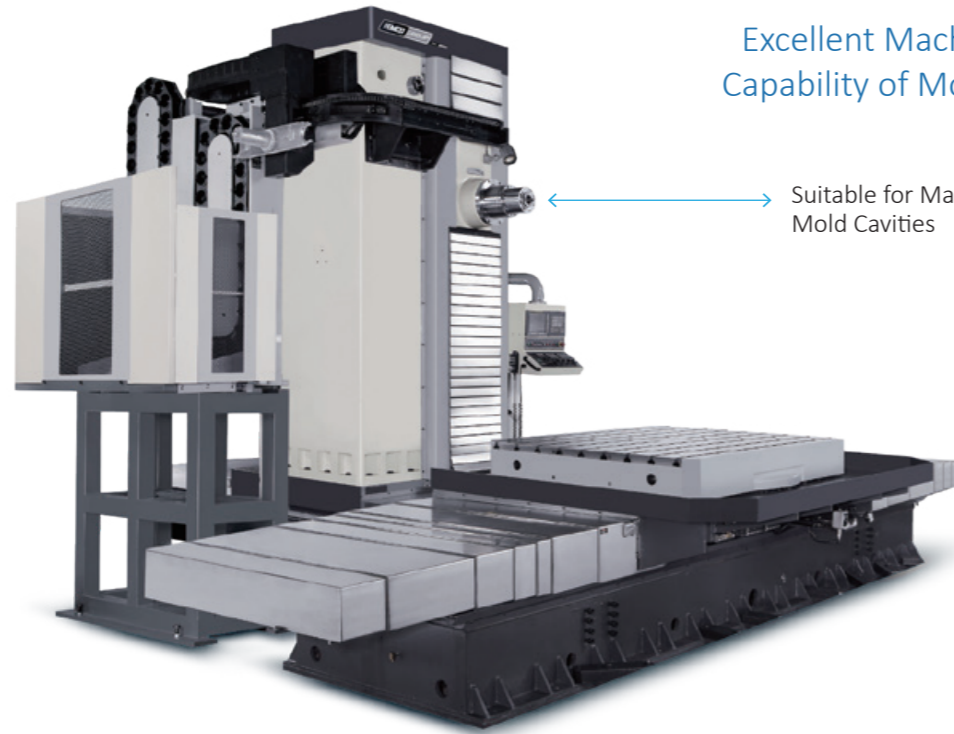

Suitable for Machining Mold Cavities

## BMC - 250T

Deep Cavity Mold Machining

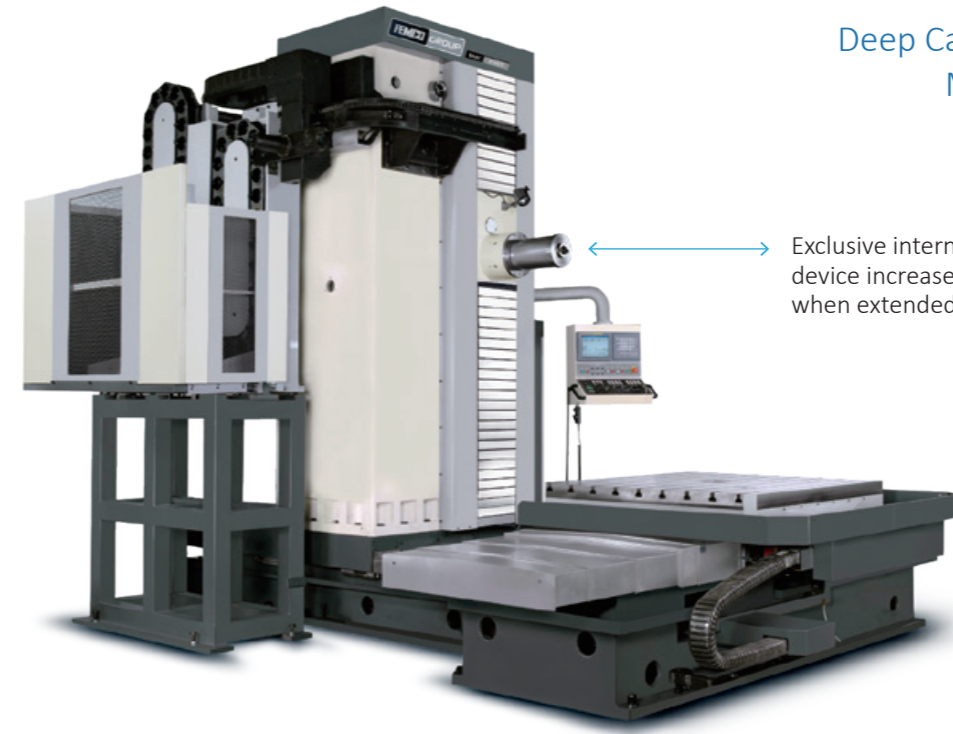

Exclusive internal clamping device increase RAM rigidity when extended

Optional Equipment



60 / 90T ATC



Right Angle Work Table

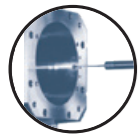

Work Piece Measurement



Tool Length Probe



Splash Guard

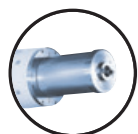

Coolant Through Spindle

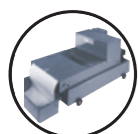

Paper Filter



Linear Scale (HDH)



Transformer

Optional Equipment



60 / 90T ATC

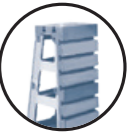

Right Angle Work Table

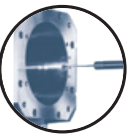

Work Piece Measurement



Tool Length Probe



Splash Guard

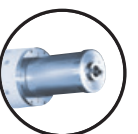

Coolant Through Spindle

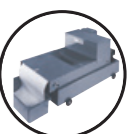

Paper Filter



Linear Scale (HDH)



Transformer

### 100HT

<b>X Axis Travel (Linear Guide Way)</b>	3000 mm
<b>Y Axis Travel (Box Way)</b>	2050 mm
<b>Z Axis Travel (Linear Guide Way)</b>	1500 mm
<b>Spindle Speed</b>	8000 rpm
<b>Spindle Bar Dia.</b>	100 mm
<b>B Axis Table</b>	0.001 degree indexing
<b>Table Size</b>	1500 mm X 2000 mm
<b>Table Load Capacity</b>	20000 kgs.

### Efficient Mold Machining Spindle Speed up to 8000 rpm

BMC-100HT are designed for medium size workpiece with high efficiency mold machining.

Table size 1500 x 2000 mm

Full casting column with firmness process maximize the rigidity of its structure and increase the precision during processing.

The build-in spindle design bring the spindle speed up to .8000 rpm.

BMC-100HT provide lots of optional devices to ultimize its accuracy to meet the customer's demand. (e.g. FAGOR linear scale, monitoring systems.)

### RAM Design Heavy Machining

BMC-250T CNC horizontal boring machine is designed with moving column structure, high speed spindle and extension RAM for heavy duty jobs, mold industries and can perform deep hole machining.

The spindle speed can go up to max. 6000rpm.

### 250T

<b>X Axis Travel</b>	2000 / 3000 mm
<b>Y Axis Travel</b>	2050 mm
<b>Z Axis Travel</b>	1500 mm
<b>W Axis Ram Travel</b>	500 mm
<b>Spindle Speed</b>	6000 rpm
<b>Spindle Bar Dia.</b>	100 mm
<b>B Axis Table</b>	0.001 degree indexing
<b>Table size</b>	1440 mm X 1600 mm
<b>Table Load Capacity</b>	8000 kgs.

**5+1 Axis (X, Y, Z, W, B, U)** Independent NC which is Programmable for All Shapes of Workpiece.  
Facing Head Is Not Suitable for Standard Spindle

# FR/FT

## Fixed Type Facing Head



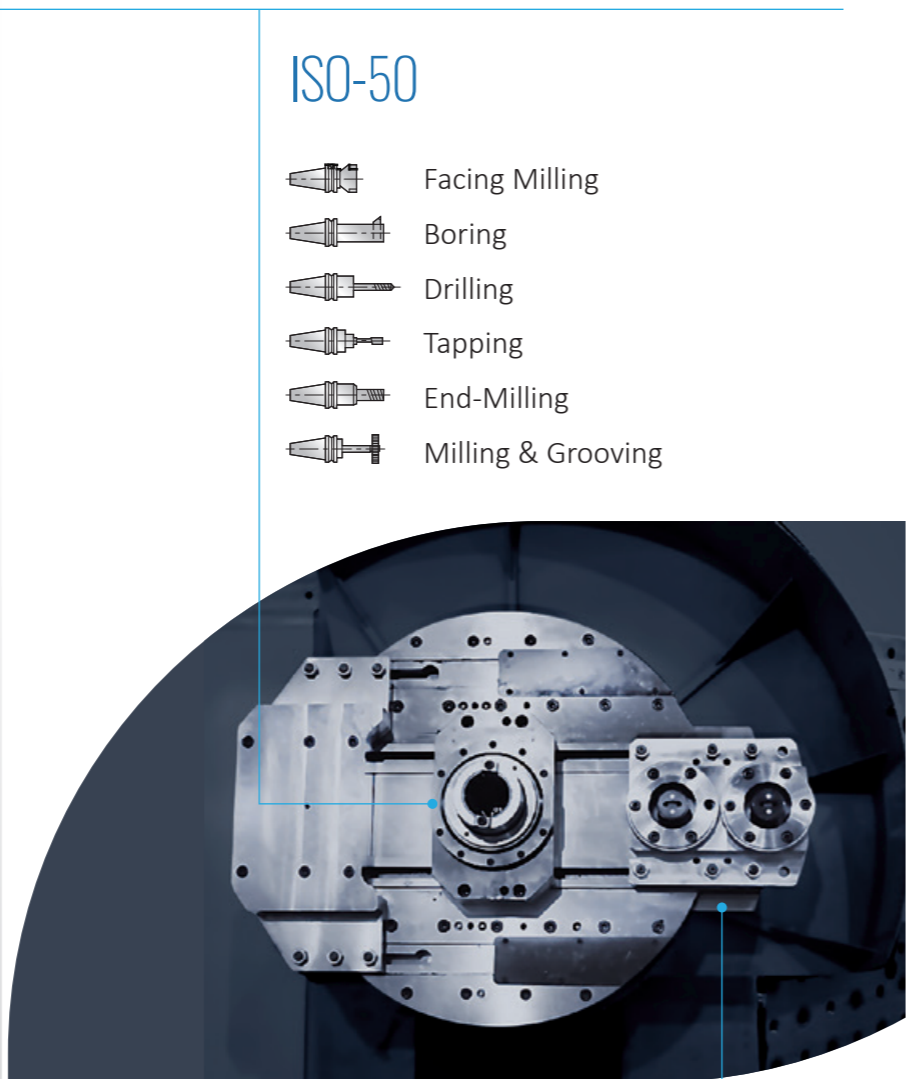

Available on all models with **110 mm** Spindle Bar Dia.

### FT Type Column-moving Special Features





Use for corner machining, internal / external taper machining, ID / OD grooving and facing on valve body, pump housing, fitting and turbine housing.

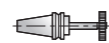

### ISO-50

-  Facing Milling
-  Boring
-  Drilling
-  Tapping
-  End-Milling
-  Milling & Grooving

### HSK-100

-  Outer O.D. (taper, sphere, contour)
-  End-Face (chamfer, groove)
-  I.D. (taper, sphere, shape)
-  Grooving (I.D., O.D. groove)
-  Threading (I.D., O.D. thread)

Standard Accessories Include

- BT Type tool ..... 1pc
- HSK Type tool ..... 1pc
- HSK Type tool .... 2pcs (optional)

# Facing Tool RF

Ø125 ~ Ø250 mm

Suitable for spindle 110 mm model

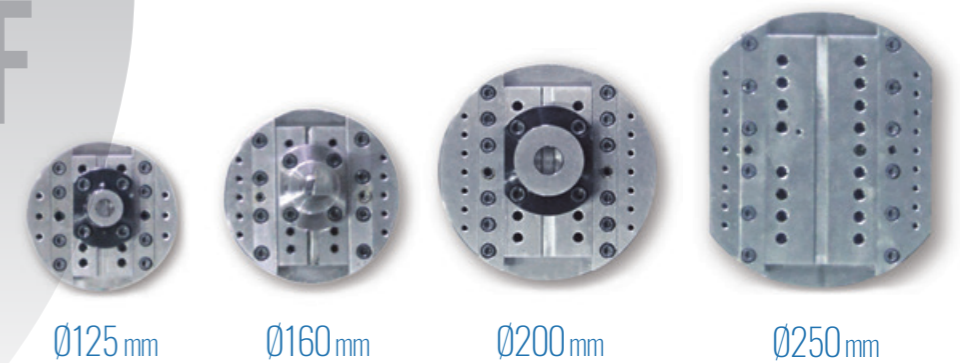

Unique Facing Tools designed for use with Automatic Tool Changer and to be stationed in ATC Magazine for flexible part processing

Facing Tools of various sizes are an exclusive FEMCO patented design.

FEMCO offers 4 different Facing Tool sizes with U-Axis for machining various bore features. These Facing Heads suitable for machining smaller diameters allow the use of the ATC for increased machining efficiency.



Facing Tool is not suitable for standard spindle

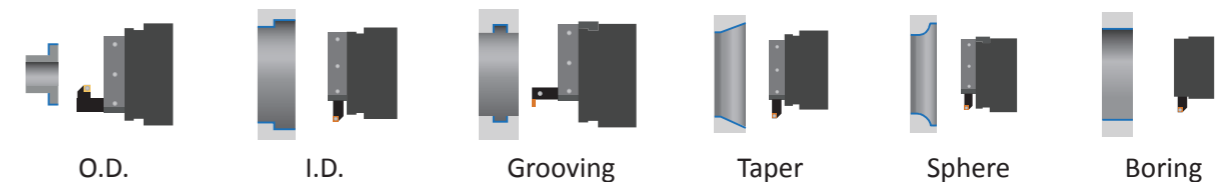

FACING HEAD (U AXIS)	Facing Head		Facing Tool	
	Parameter	Value	Value	Value
O.D.	mm	720	125 / 160 / 200 / 250	
Slide Stroke	mm	230	25 / 35 / 45 / 55	
Max. Face Machining Dia.	mm	1050	200 / 250 / 320 / 400	
Speed Range	rpm	5 ~ 250	8 ~ 3000	
Max. Torque	Nm	4593	1504	
Slide Rapid Traverse	mm/min	1500	2000	
Servo Motor	kW	1.6	1	



# FLOOR-Type Serise

## FB-135

### Floor Type Boring Milling Machine

Floor Type FB-135 brings you the massive production, outstanding rigidity and the most excellent machining performance.

#### RAM TYPE HYDROSTATIC

Max. 1800 rpm  
Max. Torque 3376 NM  
O.D. 135 mm  
RAM 360 mm

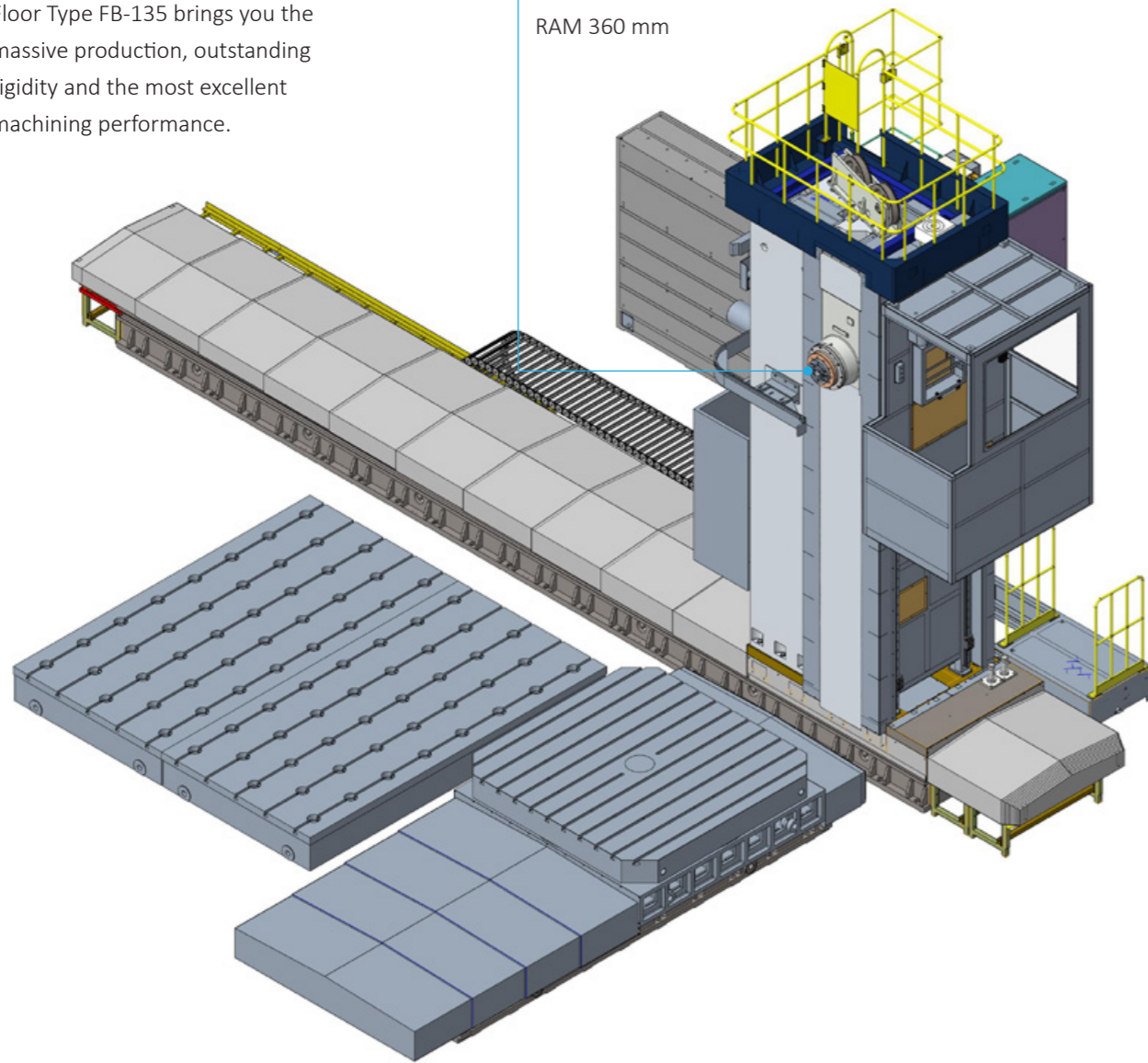

#### Promotion

- High Rigidity
- Huge Works
- High Loading
- Accurate And Precise
- Flexible for All Works
- ROI over 50%

	FB-135
X Axis Travel	6000 mm
Y Axis Travel	3500 mm
Z Axis RAM Travel	500 mm
W Axis Travel	800 mm

## The Table Swing

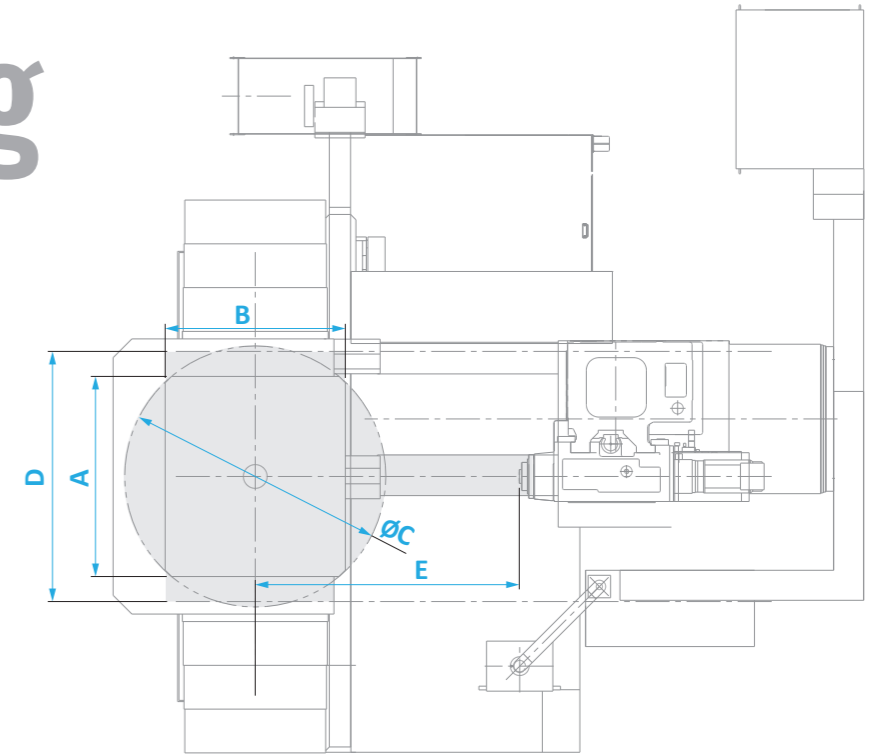

	A Length	B Width	ØC Swing	D X Axis Travel	E The distance between Table Center to Spindle Nose	Z Axis Travel	Note
BMC-110R1	1250	1120	1613	1400	1555	1050	Standard
BMC-110FR1	1250	1120	1613	1400	1185	1050	Standard
BMC-110FR1A	1250	1120	1613	1400	1130	1050	Standard
BMC-110R1APC	1100	1100	1360	1400	1555	1050	Standard
BMC-110R2 / R3	1600	1440	2087	2000/3000	2280	1650	Standard
BMC-110FR2	1600	1440	2087	2000	1910	1650	Standard
BMC-110R2 / R3	2000	1800	2625	2000/3000	2280	1650	Option
BMC-110T2	1600	1440	2087	2000	2150	1500	Standard
BMC-110T3	1600	1440	2087	3000	2150	1500	Standard
BMC-110T4	1600	1440	2087	4000	2150	1500	Standard
BMC-110FT2	1600	1440	2087	2000	1780	1500	Standard
BMC-110FT2A	1600	1440	2087	2000	1725	1500	Standard
BMC-135TN	2200 2200	2200	2780 2780	3000/4000 3000/4000	2505 3005	1500 2000	Standard Option
BMC-135RN	2000	1800	2470	2400	2338	1500	Standard
BMC-100HT	2000	1500	2419	3000	1910	1500	Standard
BMC-250T	1600	1440	2087	2000	2150	1500	Standard
FB-135	2500	2500	3201	6000	3645	500	Option



# Torque Drawing

30 min / continuous rating

--- 30 min  
— continuous rating

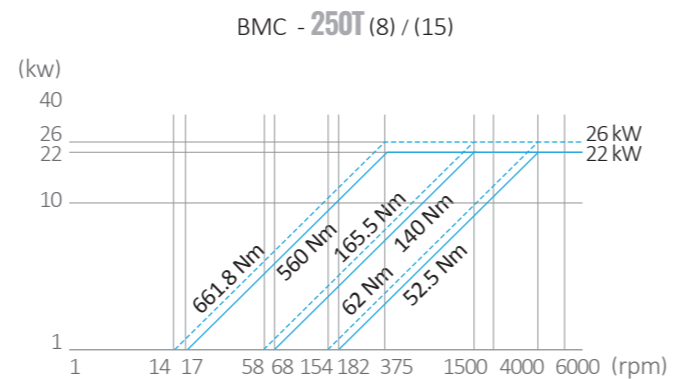
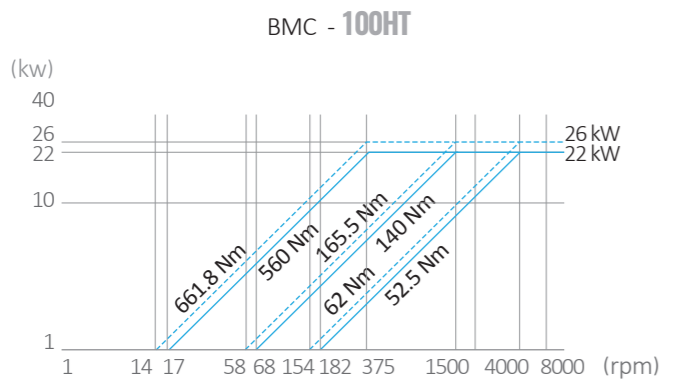
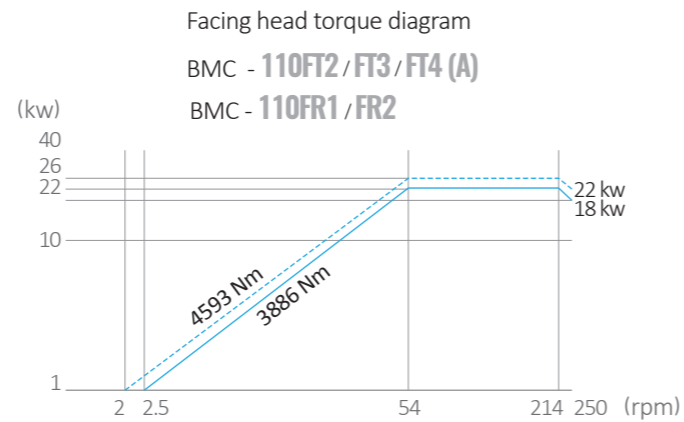
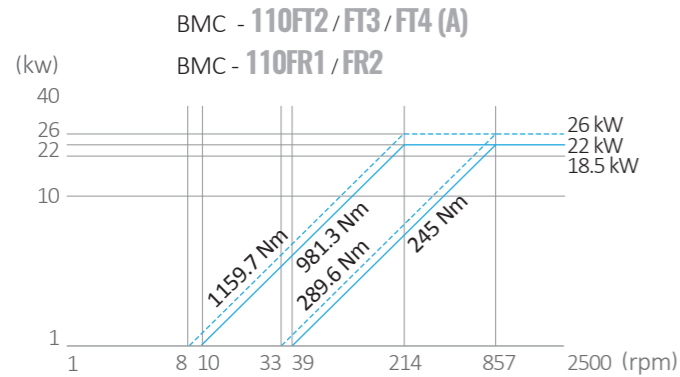
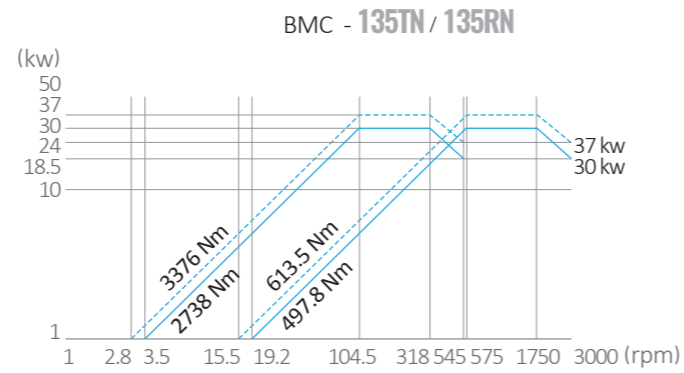
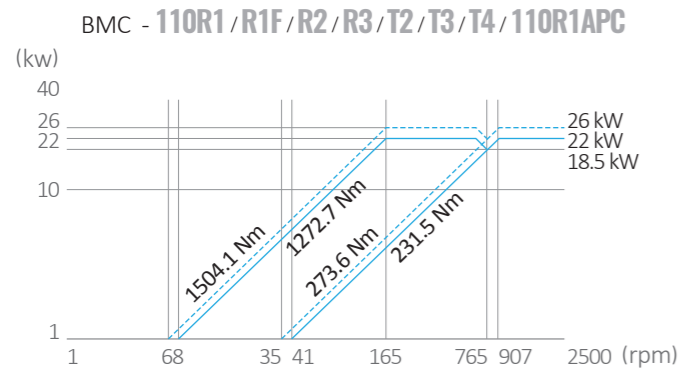

# Table & T-slot Dimension

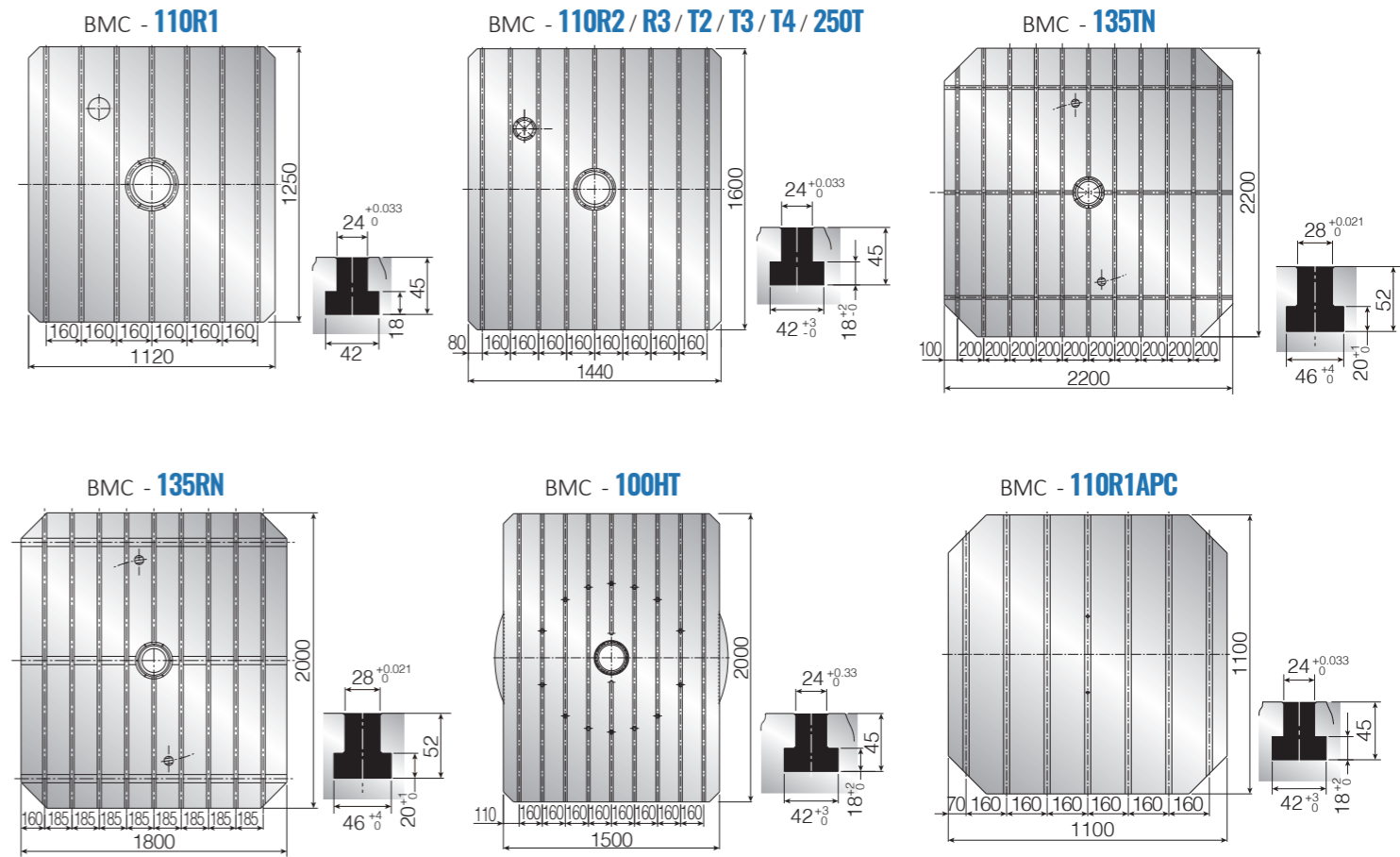

# Pull Stud Dimension

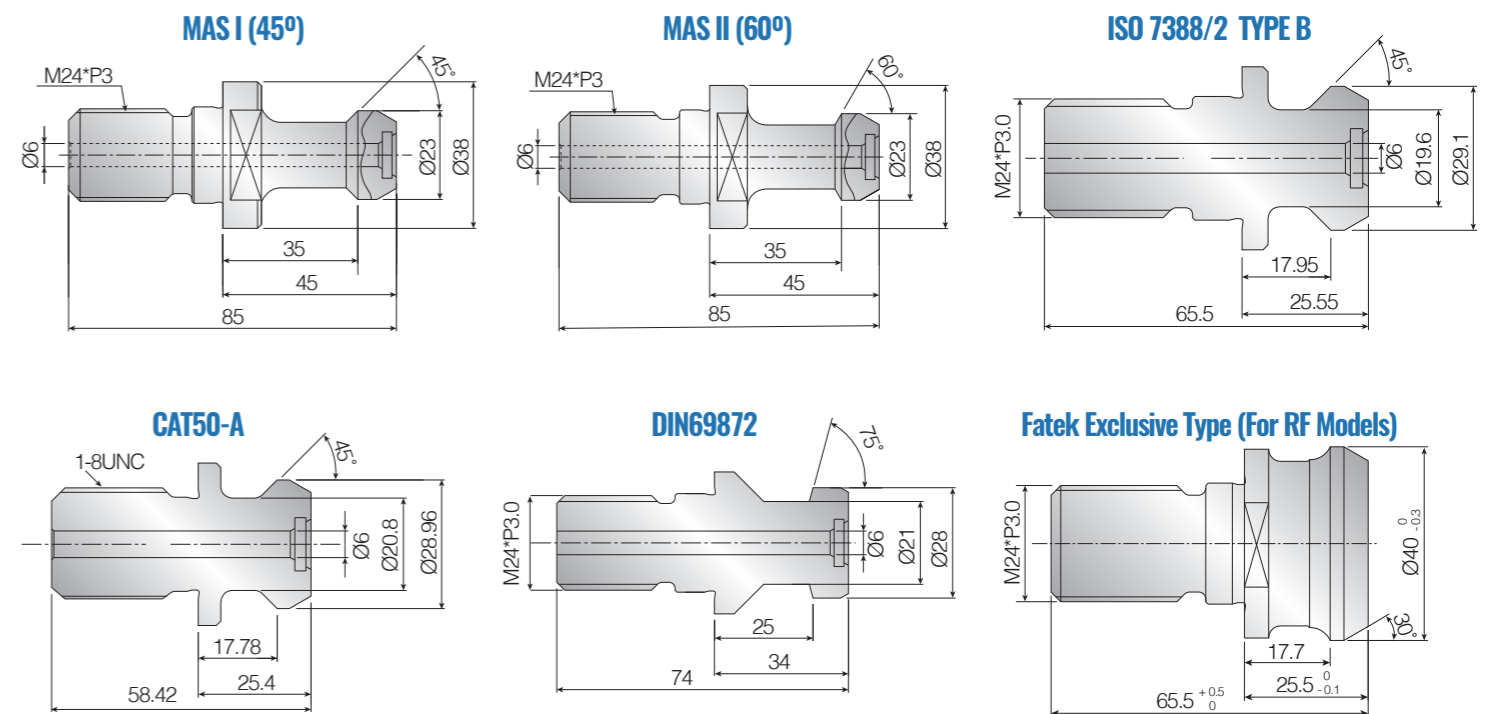

# Guarding

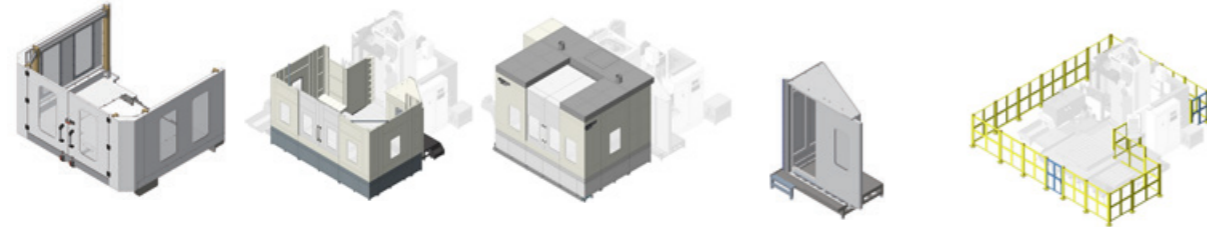

Working Table Splash Guard    Half Splash Guard    Full Splash Guard    Operator Guard    CE Safety Fence

	Working Table Splash Guard	Half Splash Guard	Full Splash Guard	Operator Guard	CE Safety Fence
R	BMC-110R1	O	X	O	※
	BMC-110R2	O	X	※	O
	BMC-110R3	O	※	X	O
T	BMC-110T2	O	O	X	O
	BMC-110T3	O	※	X	O
	BMC-110T4	O	※	X	O
	BMC-135TN	O	※	X	※
	BMC-135RN	O	※	X	※
	BMC-100HT	O	O	X	※
	BMC-250T	O	O	X	O
	FB-135	X	X	X	X
F	BMC-110R1F	O	X	O	O
	BMC-110FR1	O	X	O	O
	BMC-110FR2	O	X	※	O
	BMC-110FR3	O	※	X	O
	BMC-110FT2	O	O	X	O
	BMC-110FT3	O	※	X	O
	BMC-110FT4	O	※	X	O

O : Available    X : None    ※ : TBD

# Optional Equipment

	BMC-110R1	BMC-110R2 BMC-110R3	BMC-110T2 BMC-110T3 BMC-110T4	BMC-135TN/RN	BMC-100HT	BMC-250T
FANUC 31iM/32iM Control System	O	O	O	X	X	X
SIEMENS 840D Control System	O	O	O	O	X	X
HEIDENHAIN Control System	O	O	O	O	X	X
Spindle Motor Upgrade to 30/37 kW	O	O	O	●	X	X
Spindle Speed up to 3000 rpm	O	O	O	●	X	X
8000 rpm Build-in Spindle	O	O	O	X	●	X
Coolant Through Spindle	O	O	O	O	O	O
Spindle Extension Sleeve 250 mm	●	●	●	X	X	X
Spindle Extension Sleeve 200 mm	X	X	X	O	X	X
W Axis 700mm with Linear Scale	X	X	X	O	X	X
90 Degree Angle Head	O	O	O	O	X	X
Manual Universal Milling Head	O	O	O	O	X	X
Right Angle Work Table	O	O	O	O	O	O
Semi-Automatic Facing Head	O	O	O	X	X	X
NC Facing Head	O	O	O	X	X	X
Facing Head HSK Tools- ATC Type	O	O	O	X	X	X
Facing Tool	O	O	O	X	X	X
High Resolution Encoder	O	O	O	O	X	O
Air Conditioner for Electric Cabinet	O	O	O	O	O	O
Temperature Thermal Compensation	O	O	O	O	O	O
Paper Filter with High Pressure Coolant Tank	O	O	O	O	O	O
HDH Linear Scale for X/Y/Z Axis	O	O	O	O	O	O
Automatic Tool Changer (60/90 tools)	O	O	O	O	O	O
Tool Length Probe	O	O	O	O	O	O
Work Piece Measurement	O	O	O	O	O	O
Chip Conveyor	O	O	O	O	O	O
Oil Skimmer	O	O	O	O	O	O
Transformer	O	O	O	O	O	O
Automatic Pallet Changer	O	X	X	X	X	X

● : Standard    O : Optional    X : None



# Layout

## BMC - R Type External Dimension

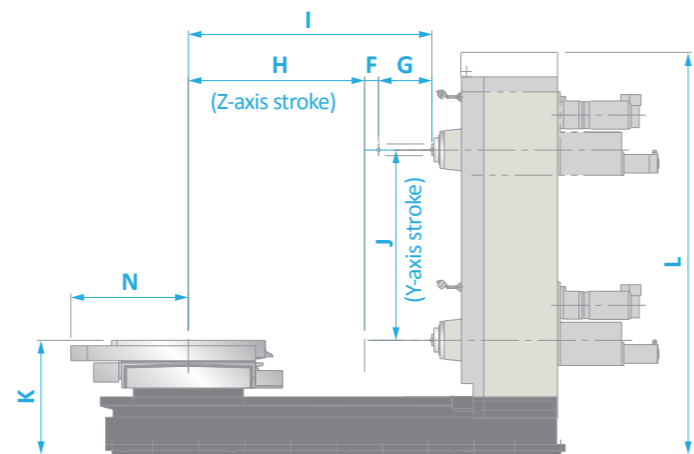
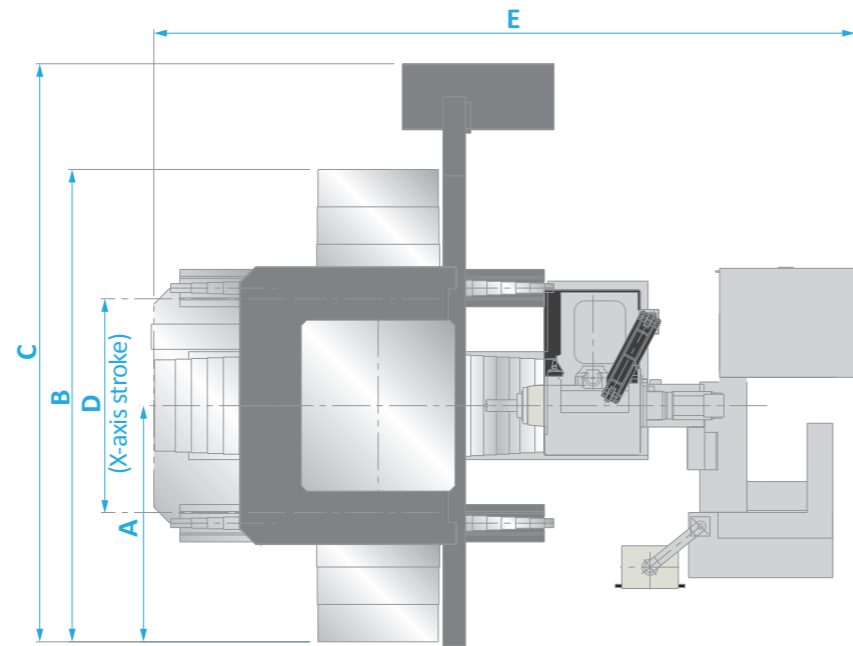

Unit:mm

	A	B	C	D	E	F	G	H	I	J	K	L	N
<b>BMC-110R1</b>	1760	3520	4740	1400	5476	5	500	1050	1555	1390	1045	3370	844
<b>BMC-110R2</b>	2210	4420	5409	2000	6566	130	500	1650	2280	1780	1070	3765	1298
<b>BMC-110R3</b>	2857.5	5715	6720	3000	6566	130	500	1650	2280	1780	1070	3765	1298
<b>BMC-110FR1</b>	1760	3520	4740	1400	5666	5	130	1050	1185	1390	1045	3470	844
<b>BMC-110FR2</b>	2210	4420	5409	2000	6566	130	130	1650	1910	1780	1070	3865	1298
<b>BMC-110FR1A</b>	1760	3520	4740	1400	5666	-160	240	1050	1130	1390	1045	3470	844
<b>BMC-110FR2A</b>	2210	4420	5409	2000	5476	-35	240	1650	1855	1780	1070	3865	1298
<b>BMC-110R1F</b>	1760	3520	4740	1400	5666	5	500	1050	1555	1390	1045	3370	844
<b>BMC-135RN</b>	2798	5596	6745	2400	6905	38	800	1500	2338	2500	1150	4865	1342

# Layout

## BMC - T Type External Dimension

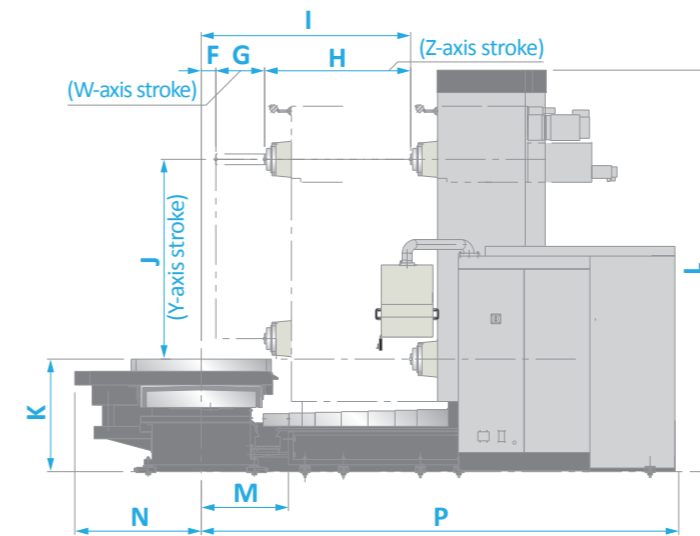
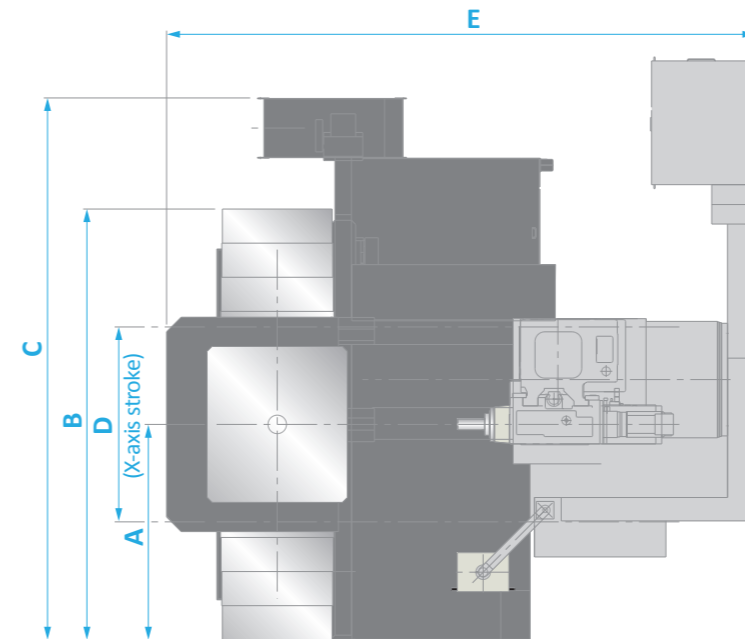

Unit:mm

	A	B	C	D	E	F	G	H	I	J	K	L	M	N	P
<b>BMC-110T2</b>	2210	4420	5560	2000	6207	150	500	1500	2150	2050	1150	4115	895	1298	4909
<b>BMC-110T3</b>	2832.5	5665	6805	3000	6207	150	500	1500	2150	2050	1150	4115	895	1298	4909
<b>BMC-110T4</b>	3499.5	6999	8035.5	4000	6207	150	500	1500	2150	2050	1150	4115	895	1298	4909
<b>BMC-110FT2</b>	2210	4420	5560	2000	6207	150	130	1500	1780	2050	1150	4115	895	1298	4909
<b>BMC-110FT3</b>	2832.5	5665	6805	3000	6207	150	130	1500	1780	2050	1150	4115	895	1298	4909
<b>BMC-110FT4</b>	3499.5	6999	8035.5	4000	6207	150	130	1500	1780	2050	1150	4115	895	1298	4909
<b>BMC-110FT2A</b>	2210	4420	5560	2000	6207	-15	240	1500	1725	2050	1150	4115	895	1298	4909
<b>BMC-135TN</b> (X:3000/Y:2500/Z:1500)	3074.5	6149	7202	3000	7462.5	205	800	1500	2505	2500	1375	5090	1289	1665	5797.5
<b>BMC-135TN</b> (X:3000/Y:3000/Z:2000)	3074.5	6149	7202	3000	8062.5	205	800	2000	3005	3000	1375	5590	1289	1665	6397.5
<b>BMC-135TN</b> (X:4000/Y:2500/Z:1500)	3574.5	7149	8204	4000	7462.5	205	800	1500	2505	2500	1375	5090	1289	1665	5797.5
<b>BMC-135TN</b> (X:4000/Y:3000/Z:2000)	3574.5	7149	8204	4000	8062.5	205	800	2000	3005	3000	1375	5590	1289	1665	6397.5
<b>BMC-100HT</b>	3402.5	6805	8036	3000	6436	410	X	1500	1910	2050	1150	4115	971.5	1259	5177
<b>BMC-250T</b>	2210	4420	5560	2000	6207	91.5	500	1500	2091.5	2050	1150	4160	895	1298	4909

# Specification

			BMC-110R1	BMC-110R2	BMC-110R3	BMC-110T2	BMC-110T3 / T4	BMC-135TN	BMC-135RN	BMC-100HT	BMC-250T(8)/(15)	FB-135	
TRAVEL	Table Cross Travel ( X )	mm	1400	2000	3000	2000	3000 / 4000	3000 / 4000	2400	3000	2000 / 3000	6000 ~ 11000	
	Head Stock Travel ( Y )	mm	1390	1780	1780	2050	2050	2500 / 3000	2500	2050	2050	3000 / 3500	
	Z Axis Travel	mm	1050	1650	1650	1500	1500	1500 / 2000	1500	1500	1500	500	
TABLE	Size	mm	1120 x 1250	1440 x 1600	1440 x 1600	1440 x 1600	1440 x 1600	2200 x 2200	1800 x 2000	1500 x 2000	1440 x 1600 / 2200 x 2200	2500 x 2500	
	Max. Loading	kg	4000	6300	6300	8000	8000	15000	10000	20000	8000 / 15000	30000	
	Rapid Rotation	rpm	1	1	1	1	1	1	1	1	1	1	
SPINDLE	Spindle Stroke (W Axis)	mm	500	500	500	500	500	800	800	—	500	800	
	Spindle Dia.	mm	110	110	110	110	110	135	135	100	100	135	
	Taper	ISO	50	50	50	50	50	50	50	50	50	50	
	Tool Shank	BT	50	50	50	50	50	50	50	50	50	50	
	Pull Stud	MAS II (I*)/ISO/CAT/DIN	MAS II (I*)/ISO/CAT/DIN	MAS II (I*)/ISO/CAT/DIN	MAS II (I*)/ISO/CAT/DIN	MAS II (I*)/ISO/CAT/DIN	MAS II (I*)/ISO/CAT/DIN	MAS II (I*)/ISO/CAT/DIN	MAS II (I*)/ISO/CAT/DIN	MAS II (I*)/ISO	MAS II (I*)/ISO/CAT/DIN	MAS II (I*)/ISO/CAT/DIN	
	Milling Spindle Dia.	mm	225	225	225	225	225	250	250	—	RAM TYPE: 250	250	
	Spindle Motor (continuous/30 min rated)	kW	22 / 26	22 / 26	22 / 26	22 / 26	22 / 26	30 / 37	30 / 37	22 / 26	22 / 26	22 / 26	30 / 37
	Spindle Speed Range_Low	rpm	8 ~ 454	8 ~ 454	8 ~ 454	8 ~ 454	8 ~ 454	10 ~ 575	10 ~ 575	17 ~ 2000	17 ~ 1500	17 ~ 1500	10 ~ 575
Spindle Speed Range_High	rpm	455 ~ 2500	455 ~ 2500	455 ~ 2500	455 ~ 2500	455 ~ 2500	576 ~ 3000	576 ~ 3000	2001 ~ 8000	1501 ~ 6000	1501 ~ 6000	576 ~ 1800	
AUTOMATIC TOOL CHANGE SYSTEM (ATC)	Tool Storage Capacity		60	60 / 90	60 / 90	60 / 90	60 / 90	60	60	60 / 90	60 / 90	60 / 90	
	Max. Tool Dia. ( adjacent )	mm	245 ( 125 )	245 ( 125 )	245 ( 125 )	250 ( 125 )	250 ( 125 )	245 ( 125 )	245 ( 125 )	250 ( 125 )	250 ( 125 )	245 / 125	
	Max. Tool Length	mm	400	400	400	400	400	400	400	400	400	400	
	Max. Tool Weight	kg	25	25	25	25	25	25	25	25	25	25	
	Tool to Tool Exchange Time	sec	13	13	13	13	13	11	11	13	13	11	
SERVO MOTOR	X Axis	kW	6 ( α iF40 / 3000 )	6 ( α iF40 / 3000 )	6 ( α iF40 / 3000 )	7 ( α iF30 / 4000 ) + G.B.	7 ( α iF30 / 4000 ) + G.B.	9 ( α iF40 / 3000 ) + G.B.	9 ( α iF40 / 3000 )	6 ( α iF40 / 3000 )	7 ( α iF30 / 4000 ) + G.B. 9 ( α iF40 / 3000 ) + G.B.	9 ( α iF40 / 3000 )	
	Y Axis	kW	7 ( α iF30 / 4000 )	7 ( α iF30 / 4000 )	7 ( α iF30 / 4000 )	7 ( α iF30 / 4000 )	7 ( α iF30 / 4000 )	9 ( α iF40 / 3000 ) + G.B.	9 ( α iF40 / 3000 ) + G.B.	7 ( α iF30 / 4000 )	7 ( α iF30 / 4000 ) + GB	9 ( α iF40 / 3000 ) + G.B.	
	Z Axis	kW	6 ( α iF40 / 3000 )	6 ( α iF40 / 3000 )	6 ( α iF40 / 3000 )	6 ( α iF40 / 3000 )	6 ( α iF40 / 3000 )	9 ( α iF40 / 3000 ) + G.B.	9 ( α iF40 / 3000 )	6 ( α iF40 / 3000 )	6 ( α iF40 / 3000 )	7 ( α iF30 / 4000 )	
	W Axis	kW	4 ( α iF22 / 3000 )	4 ( α iF22 / 3000 )	4 ( α iF22 / 3000 )	4 ( α iF22 / 3000 )	4 ( α iF22 / 3000 )	7 ( α iF30 / 4000 )	7 ( α iF30 / 4000 )	—	4 ( α iF22 / 3000 )	7 ( α iF30 / 4000 )	
	B Axis	kW	4 ( α iF22 / 3000 )	4 ( α iF22 / 3000 )	4 ( α iF22 / 3000 )	4 ( α iF22 / 3000 )	4 ( α iF22 / 3000 )	7 ( α iF30 / 4000 )	7 ( α iF30 / 4000 )	7 ( α iF30 / 4000 )	4 ( α iF22 / 3000 ) / 7 ( α iF30 / 4000 )	9 ( α iF40 / 3000 )	
	V Axis	kW	—	—	—	—	—	—	—	—	—	—	7 ( α iF30 / 4000 ) + G.B
CONTROL AXIS	Control Axis		4 ( 5 for 31iM / 32iM )	4 ( 5 for 31iM / 32iM )	4 ( 5 for 31iM / 32iM )	5 ( for31iM / 32iM )	5 ( for31iM / 32iM )	4	4	4	5	6	
	Simultaneous Controlled Axis		4	4	4	4	4	4	4	4	4	4	
RAPID TRAVERSE	X / Y / Z Axis	m/min	10	10	10	10 / 12 / 12	10 / 12 / 12	10 / 8 / 10	10 / 8 / 10	12	10 / 10 / 12	10 / 8 / 10	
	W Axis	m/min	4	4	4	4	4	4	4	—	4	6	
FEED RATE	Feed Rate of Every Axis	mm/min	0 ~ 4000	0 ~ 4000	0 ~ 4000	0 ~ 4000	0 ~ 4000	0 ~ 3000	0 ~ 3000	0 ~ 4000	0 ~ 4000	0 ~ 4000	
MACHINE WEIGHT	Net Weight	kg	16000	19000	21000	24000	25000 / 26000	34000 ~ 43000		24300	25000 / 32000	—	
MACHINE DIMENSION	Height	mm	3370	3800	3800	4100	4100	5100 / 5600	4865	4100	4370	7155	
	Floor Space	mm	6600 x 5700	7700 x 6200	7700 x 7600	7100 x 7060	7100 x 7800 / 7100 x 9100	7200 x 7500 / 8200 x 8000	8000 x 7600	8100 x 6500	7250 x 7060 / 7700 x 8100	—	
LINEAR SCALE			X / Y / Z	X / Y / Z	X / Y / Z	X / Y / Z	X / Y / Z	X / Y / Z	X / Y / Z	X / Y / Z	X / Y / Z	X / Y / Z	
POWER CAPACITY		kVA	75	75	75	77	77	102	—	70	80	114	
CONTROL SYSTEM			FANUC (Qimf) *OPT: SIEMENS, HEIDENHAIN										